

機械特點 DIAMOND SERIES :

單主軸單刀塔 Single Turret

伺服馬達換刀快速，可大大提高加工效率。
Servo Turret as standard accessory to increase turning efficiency.

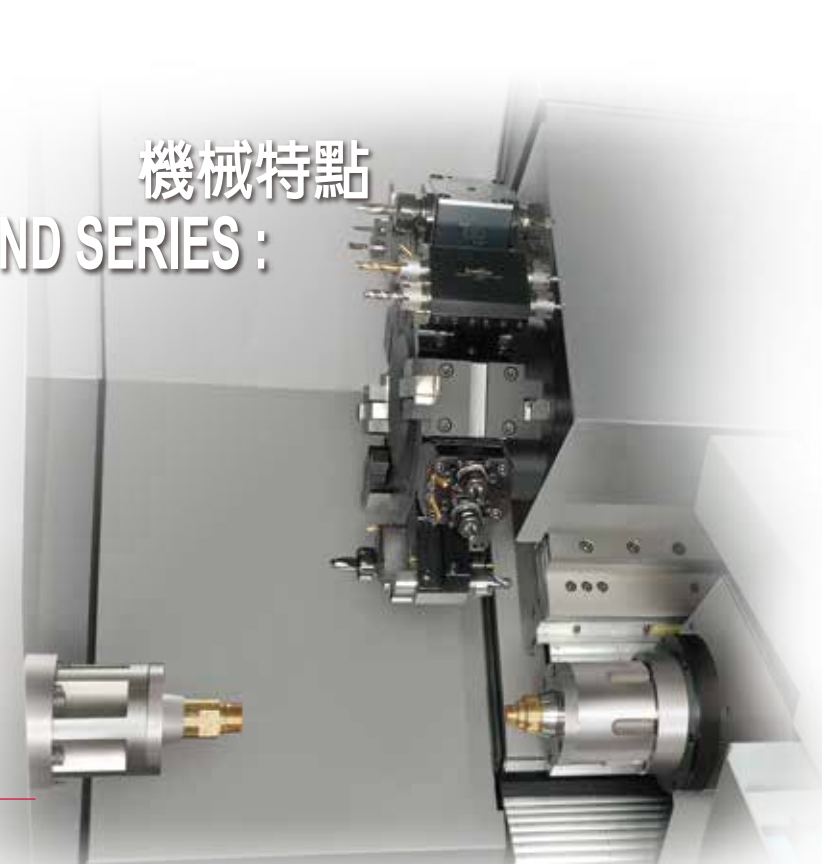

主軸及副主軸可互相搭配做正面及背面加工，一機完成，無須二次加工，除了可提高加工效率外，更能節省加工生產時間。
Main and sub-spindle enable separate operations and boosting productivity.

雙主軸設計 Double Spindle

T-plus單主軸：機械規格 T-plus Single Spindle: Machine Specification

項目	ITEMS	單位	T-plus 42	T-plus 52	T-plus 60
最大加工外徑(配三爪)	Max. machining dia.(with 3 jaws chuck)	mm	Ø130	Ø300	Ø350
最大加工長度(配尾座)	Max. machining length (with tail-stock)	mm	400	400	400
滑座上旋徑	Swing over cross slide	mm	350	350	350
X軸行程	X axis travel	mm	200	200	200
Z軸行程	Z axis travel	mm	480	480	480
選配Y軸行程	Opt. Y axis travel	mm	70	70	70
主軸貫通孔徑	Bore of spindle	mm	55	60	88
棒材容納直徑	Max. bar feeding dia.	mm	42	52	60/80(opt.)
主軸鼻端	Spindle nose	mm	A2-5	A2-6	A2-6/A2-8(opt.)
主軸夾頭	Spindle chuck	inch	6"	8"	10"/12"(opt.)
主軸馬達	Spindle motor		11kW/15HP	11kW/15HP	15kW/20HP
Z軸馬達	Z axis motor		1 kW	1 kW	1 kW
X軸 / 選配Y軸馬達	X axis / Opt. Y axis motor		1.5 kW	1.5 kW	1.5 kW
選配動力刀塔鑽銑馬達	Opt. driven tools motor for power turret		3.7kW/5HP	3.7kW/5HP	3.7kW/5HP
主軸轉速	Spindle speed	rpm	100-6000	100-4000	100-3500, 100-3000(opt.)
快速位移 (X,Z軸)	Rapid traverse (X, Z axes)	m/min	12	12	12
最小輸入單位	Min. input unit	mm	0.001	0.001	0.001
使用刀具(選配動力刀塔)	Cutting tool size(opt. power turret)		□25 (□20)	□25 (□20)	□25(□20)
最大擴孔刀具	Max. bore size of tool	mm	Ø32	Ø32	Ø32
冷卻幫浦馬達	Coolant pump motor	mm	1HP	1HP	1HP
機械尺寸	含鐵屑機	Dimension	Attached Chip conveyor		
	未含鐵屑機		Without Chip conveyor		
機械淨重	Weight	kg	3588 / 3788 (opt. Y axis)	3628 / 3828 (opt. Y axis)	3789 / 3989 (opt. Y axis)

◆標註：(opt.)是提供主軸加大到75mm ◆Remark：(opt.) is for spindle increase to 75mm
因長期研發，機械設計如有變更恕不另行通知。 We reserve the right to change the above design without prior notification.

刀塔 TURRET

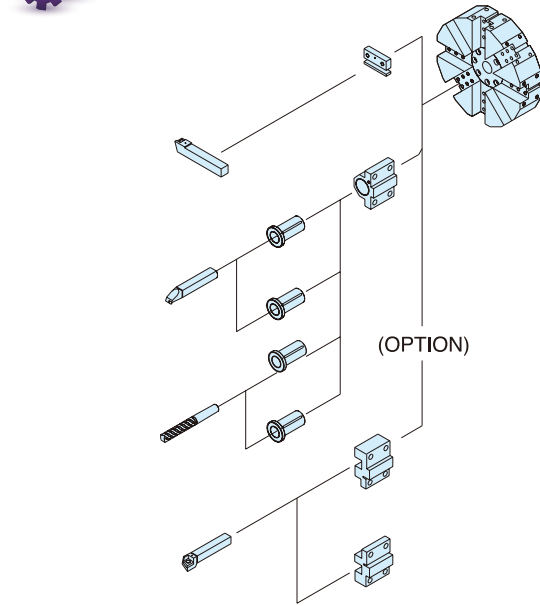

加工範圍 WORKING RANGE

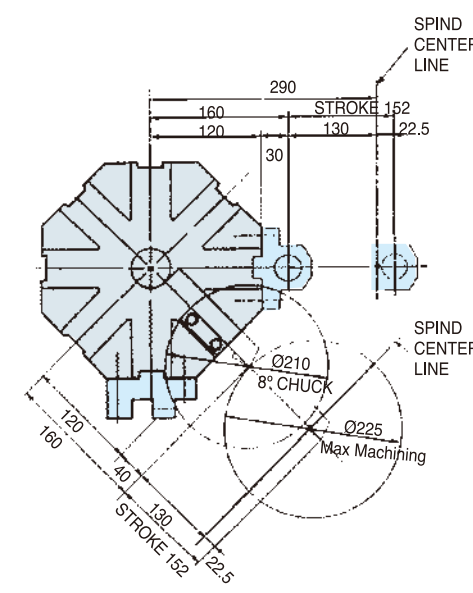

雙主軸配動力刀塔(選配Y軸) DOUBLE SPINDLE WITH POWER TURRET (OPT. Y AXIS)

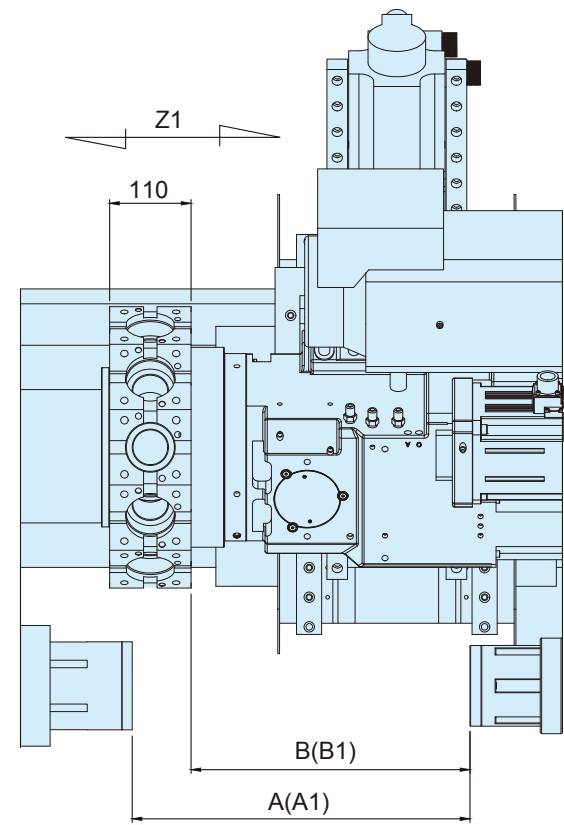

Unit:mm

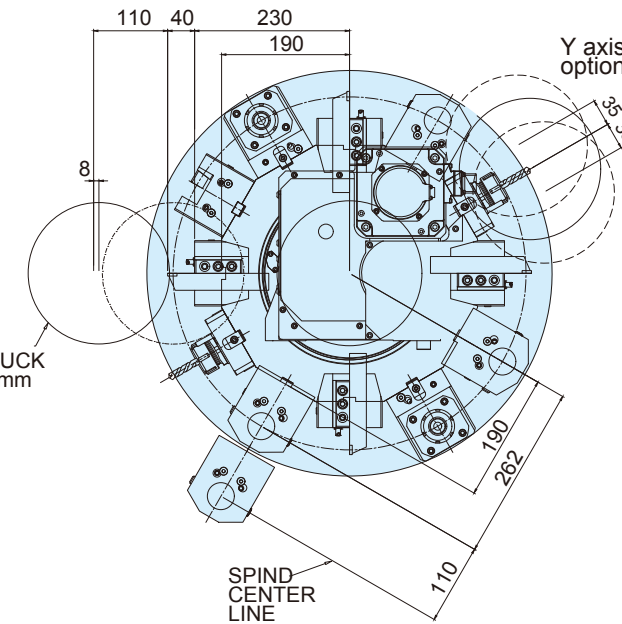

	A	A1	B	B1	Z1
T-plus 42	450		330		360
T-plus 52		420		300	360
T-plus 60		420		300	360



PO LY GIM

富格蘭科技有限公司
PO LY GIM MACHINERY CO., LTD.

Web://www.polygim.com.tw

台灣苗栗縣銅鑼鄉竹森村149之1號 TEL: 886-37-981220 • 980599 FAX: 886-37-985306
No. 149-1, Zhusen Village, Tongluo Shiang, Miao-Li County 366, Taiwan. • E-Mail: polygim@ms69.hinet.net

T-plus

堅固 · 效率 · 經濟 · 精度

CNC LATHE

寶麗金電腦車床 T-PLUS SERIES : 42 / 52 / 60



RIGID · PRECISION · SPEED · STABILITY

富格蘭科技有限公司
PO LY GIM MACHINERY CO., LTD.

L.Y.S-Cat-2021.5.23