

精簡的設計 · 人性化操作面板 · 非常適合量產加工！

方軌設計，讓重切削更容易！

SIMPLIFIED AND HUMANITY DESIGN IS SUITABLE FOR MASS PRODUCTION!

HIGH RIGIDITY DESIGN IS GOOD AND EASY FOR HEAVY CUTTING!



MODEL: **PLG-42**

- 1 筒式刀座，讓換刀更快速、準確。 Gang type tool makes tool change easily.
- 2 加寬的除屑機，讓除屑工作更容易。 Wide chip conveyor makes chip removal easily.
- 3 可另行選購8支刀刀塔。 Optional 8-station turret, offer more flexible operation.
- 4 工件收集器。 Part catcher offers automatic operation.



MODEL: **PLG-42**

**PLG-42 配門型機械手 PLG-42 With Gantry Robot**



MODEL: **PLG-52  
PLG-60  
PLG-75**

高精度滾珠螺桿及軸承，確保您的精密加工。



成品輸送裝置  
Part conveyor



尾座 Tail Stock  
可程式頂針行程100mm  
Programmable quill with stroke 100mm and MT4 taper.



排屑機 Chip Conveyor

“伺服馬達鑽孔機” Power Tool

動力鑽銼刀具刀座可做多邊加工  
Power tool holder can operate multilateral parts



MODEL: **PLG-42L**

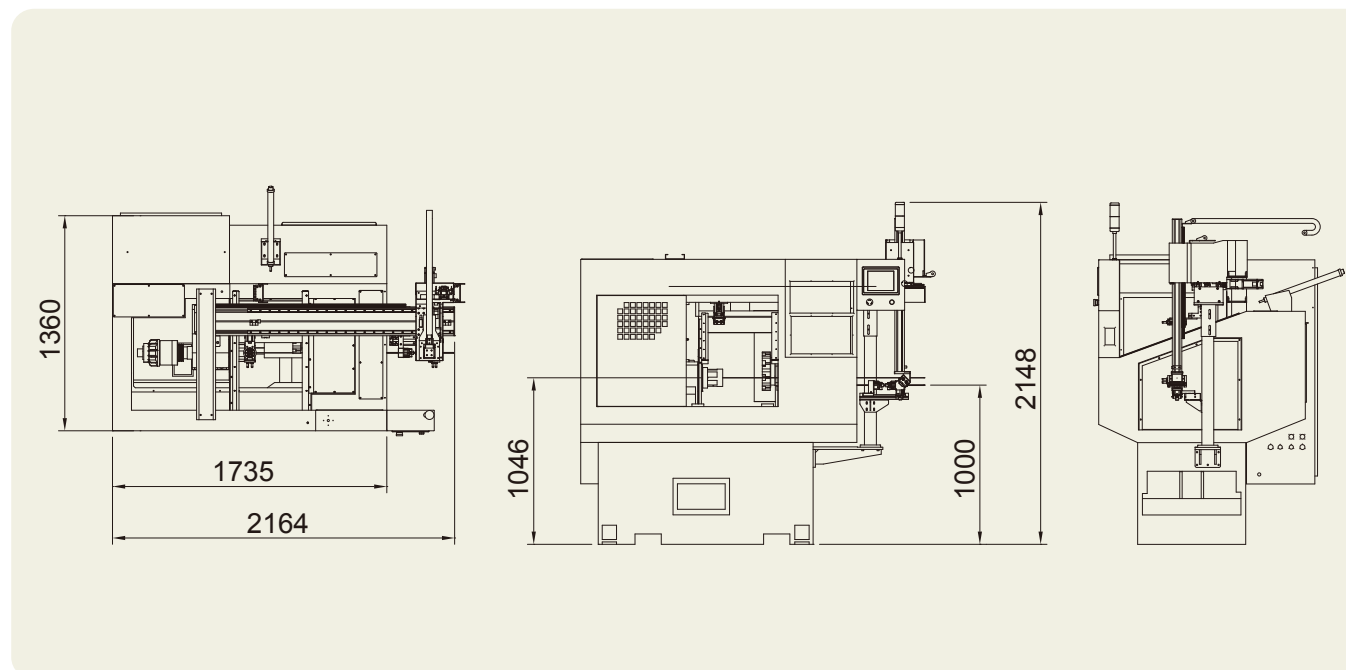

油壓鑽孔機系列

配置專用油壓系統，可任選以下鑽孔機，做特殊鑽孔功能

Power Tools Series

Any of hydraulic parts below is optional accessory to satisfy users' every option.

