



COLLET CHUCK

● 主軸搭配筒夾型夾頭
Spindle mounting collet chuck

CNC電腦車床無須動力刀塔 但功能更勝動力刀塔

*A Cnc Lathe Without
Power Turret
But Function Super
Then Power Turret*

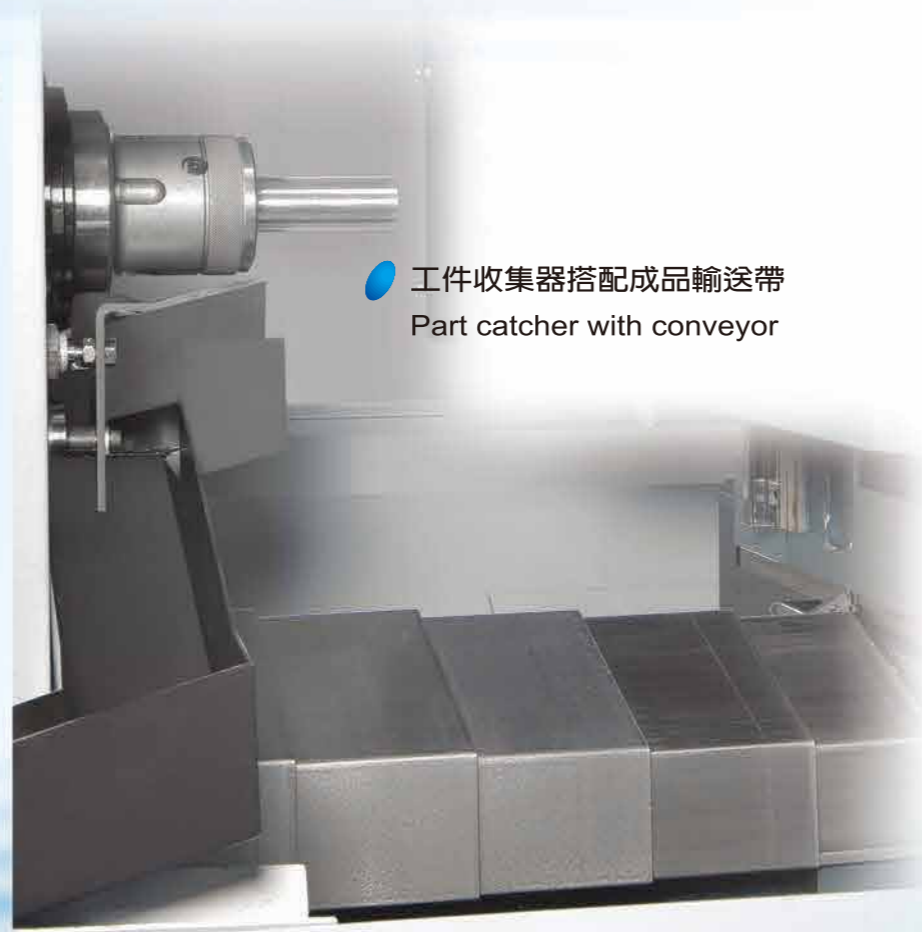

● 工件收集器搭配成品輸送帶
Part catcher with conveyor

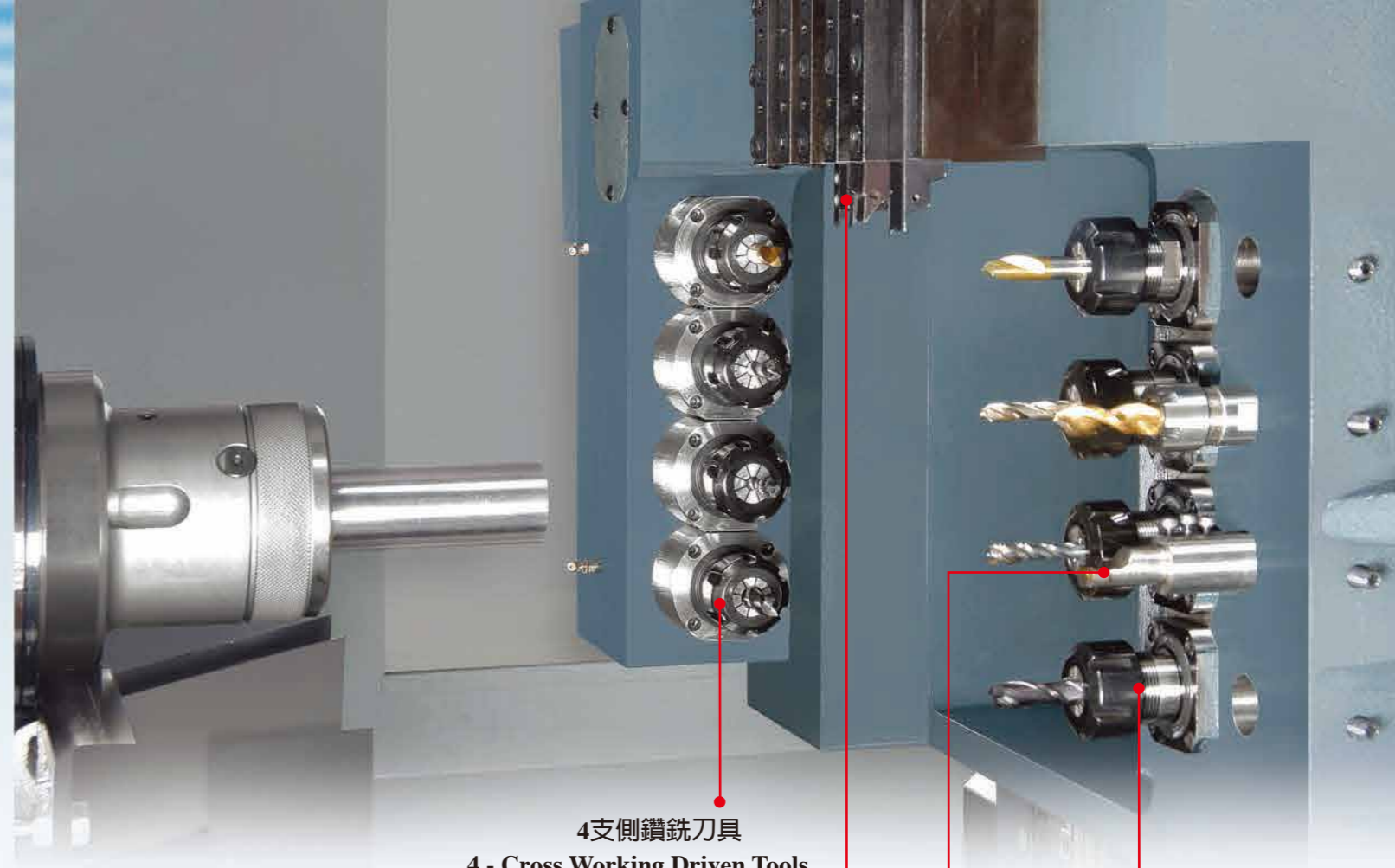

4支側鑽銑刀具
4 - Cross Working Driven Tools

5支外徑刀具 (42型配6支外徑刀)
5 pcs O.D. turning tools
(42 type with 6 pcs O.D. turning tools)

6支固定式內徑刀
6 - I.D. stationary Tools

4支正面鑽銑刀具
4 - Front Working Driven Tools

5支外徑刀具 (42型配6支外徑刀)
5 pcs O.D. turning tools
(42 type with 6 pcs O.D. turning tools)

4支側鑽銑刀具
4 - Cross Working Driven Tools

6支固定式內徑刀
6 - I.D. stationary Tools

4支正面鑽銑刀具
4 - Front Working Driven Tools

