

- 取消B軸配8支斜角度刀具刀座換配端側一體刀座  
Cancel the 8 pcs B-axis bevel driven tool holder and replace a off-center driven tool holder

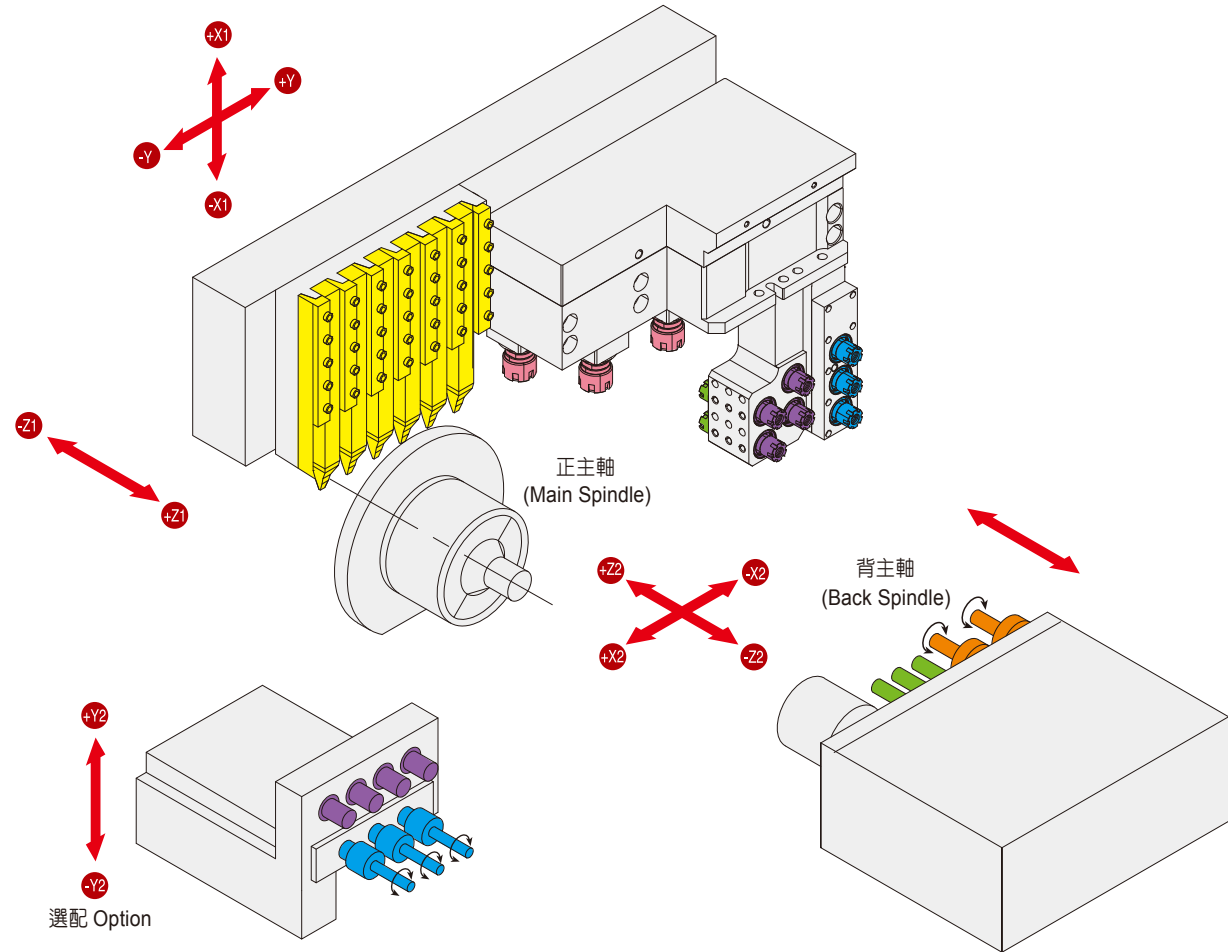

- 7支外徑刀具刀座(42型6支) 7 pcs O.D Turning tool holder ( 42 CSL 6pcs)
- 6支側面鑽銑刀具刀座 6 pcs Cross working driven tool holder
- 4支+3支(42型2支)正面內徑 刀具刀座 4 pcs + 3 pcs (42 CSL 2pcs) Front I.D stationary tool holder
- 3支+2支正面鑽銑刀具刀座 3 pcs + 2 pcs Front working driven tool holder
- 4支+4支背面內徑刀具刀座 4 pcs + 4 pcs Back I.D stationary tool holder
- 3支+3支背面鑽銑刀具刀座 3 pcs + 3 pcs Back working driven tool holder

### 標準配件 STANDARD ACCESSORIES :

- ◆ 控制器: 發那科0i-TF PLUS
- ◆ 主軸C軸定位
- ◆ 背主軸5°定位
- ◆ 工作燈
- ◆ 冷卻系統
- ◆ 正面內徑刀具刀座 ... 3支(42型2支)
- ◆ 背面內徑刀具刀座 ... 4支
- ◆ 正面/背面內徑刀具刀座 ... 4/4支
- ◆ 正面/背面鑽銑刀具刀座 ... 3/3支
- ◆ 側面鑽銑刀具刀座 ... 6或5支(配Evermore)

- ◆ Controller : Fanuc 0i -TF PLUS
- ◆ Main spindle C axis orientation
- ◆ Back spindle 5° orientation
- ◆ Working light
- ◆ Coolant system
- ◆ Part off detective sensor
- ◆ Part catcher
- ◆ Live bushing
- ◆ O.D turning tool holder ..... 7pcs (42CSL 6pcs)
- ◆ Front I.D stationary tool holder ... 3pcs (42CSL 2pcs)
- ◆ Back I.D stationary tool holder ..... 4pcs
- ◆ Front/Back I.D stationary tool holder ..... 4/4pcs
- ◆ Front/Back working driven tool holder ..... 3/3pcs
- ◆ Cross working driven tool holder ..... 6 or 5pcs(with Evermore)

### 選擇附件 OPTION ACCESSORIES :

- ◆ 控制器: 三菱 M80
- ◆ 正面鑽銑刀具刀座 ... 2支
- ◆ 背面鑽銑刀具刀座 ... 3 / 7 支(選配Evermore)
- ◆ CS軸(0.001°定位-發那科 / 0.01°定位-三菱) ... 主軸
- ◆ C軸定位 ... 背主軸
- ◆ 排屑機 + 鐵屑車
- ◆ 粗料套筒
- ◆ Y2軸

- ◆ Controller : Mitsubishi M80
- ◆ Front working driven tool holder ..... 2pcs
- ◆ Back working driven tool holder ..... 3 / 7pcs(Opt. Evermore)
- ◆ CS axis ( 0.001° orientation-Fanuc / 0.01° orientation-Mitsubishi) ..... Main spindle
- ◆ C axis ..... Sub-spindle
- ◆ Chip conveyer + Bucket
- ◆ Rough material bushing
- ◆ Y2 Axis

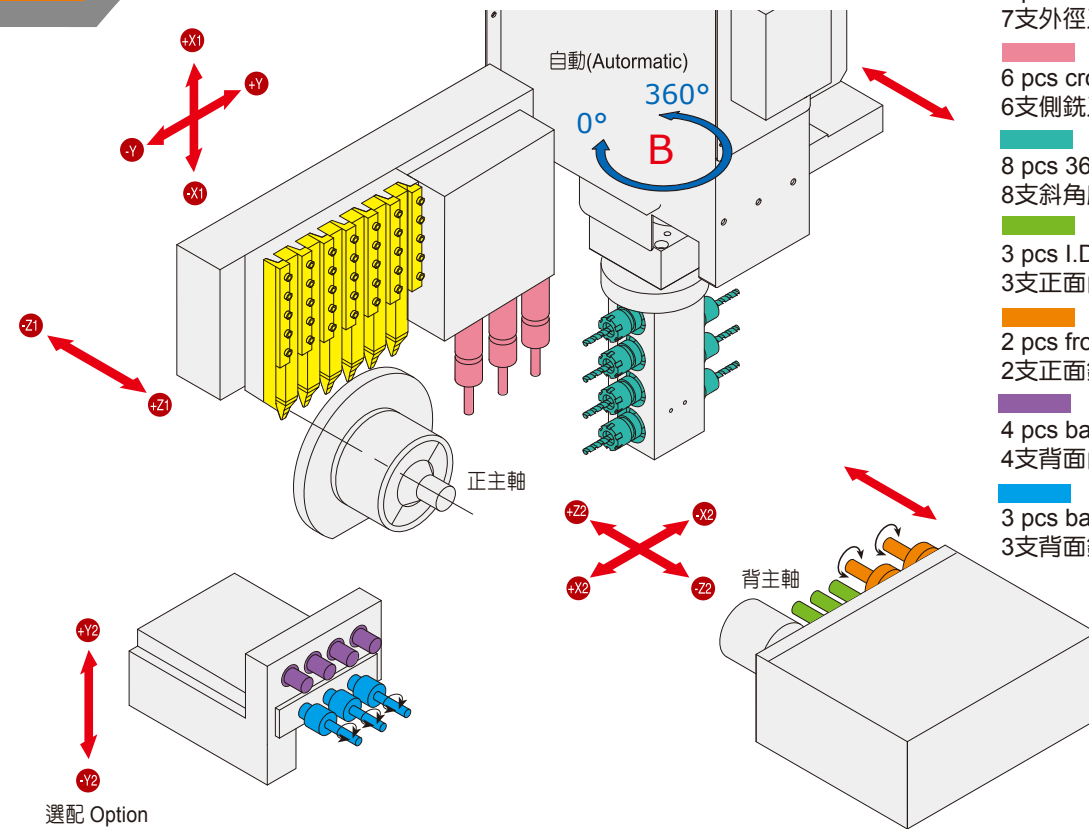

- 7 pcs O.D turning tool holder (42CSL 6pcs)  
7支外徑刀具刀座(42型6支)
- 6 pcs cross working driven tool holder  
6支側銑刀具刀座
- 8 pcs 360° B axis bevel driven tool holder  
8支斜角度鑽銑刀具刀座
- 3 pcs I.D stationary tool holder ( 42CSL 2 pcs)  
3支正面內徑刀具刀座(42型2支)
- 2 pcs front off-center driven tool holder  
2支正面鑽銑刀具刀座
- 4 pcs back I.D stationary tool holder  
4支背面內徑刀具刀座
- 3 pcs back off-center driven tool holder  
3支背面鑽銑刀具刀座

有導套之主軸構造  
Using Live Bushing  
with Guide Bush

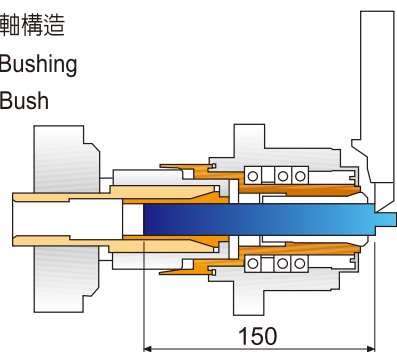

剩餘材料 Remnant Material 150 mm

無導套之主軸構造  
Using Rough Material Bushing  
without Guide Bush

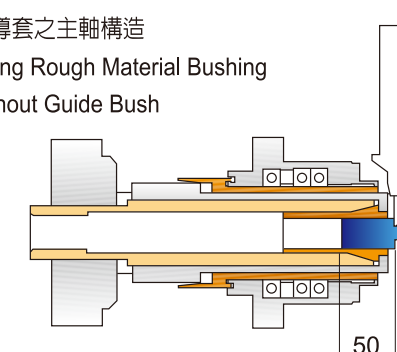

剩餘材料 Remnant Material 50 mm

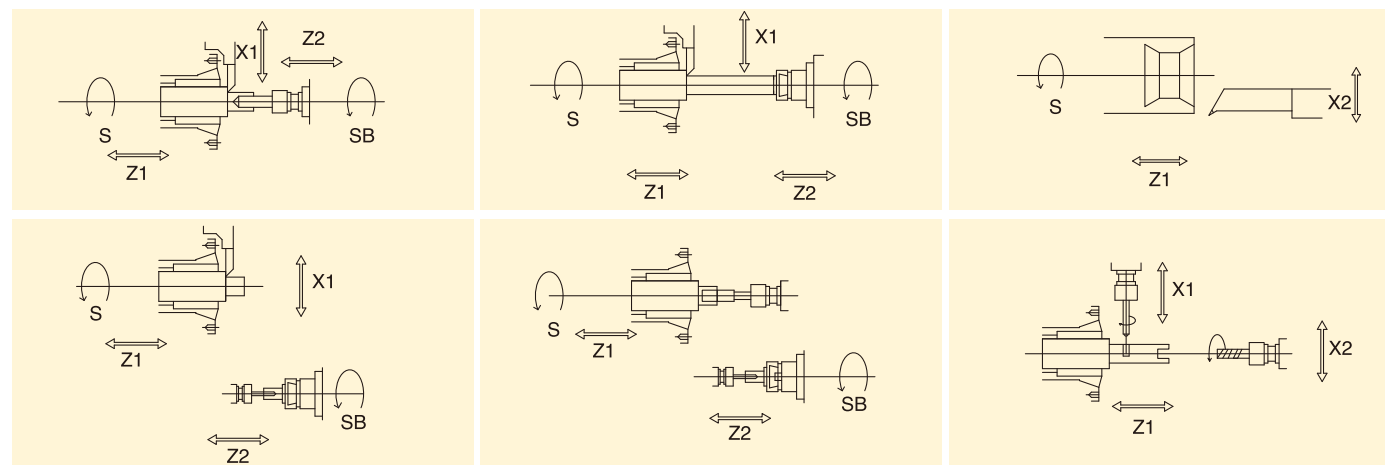

# DIAMOND CSL

## 走心式CNC自動車床 25/32/42 SERIES

### SWISS TYPE CNC AUTO LATHE

SIMPLICITY • PRECISION • SPEED • DURABILITY • STABILITY

