

SWISS TYPE CNC AUTO LATHE

● 走心式CNC自動車床



● 4 支固定內徑刀具刀座
4 pcs I.D. stationary tool holder

● 6 支外徑刀具刀座
6 pcs O.D. turning tool holder

● 刀具系統圖 TOOLS LAYOUT

TOOL HOLDER (C)-----選配簡易背軸 OPT. SIMPLE SUB-SPINDLE

DIAMOND 12/16: TOOL HOLDER(A)
DIAMOND 12CS/16CS: TOOL HOLDER(A+B)

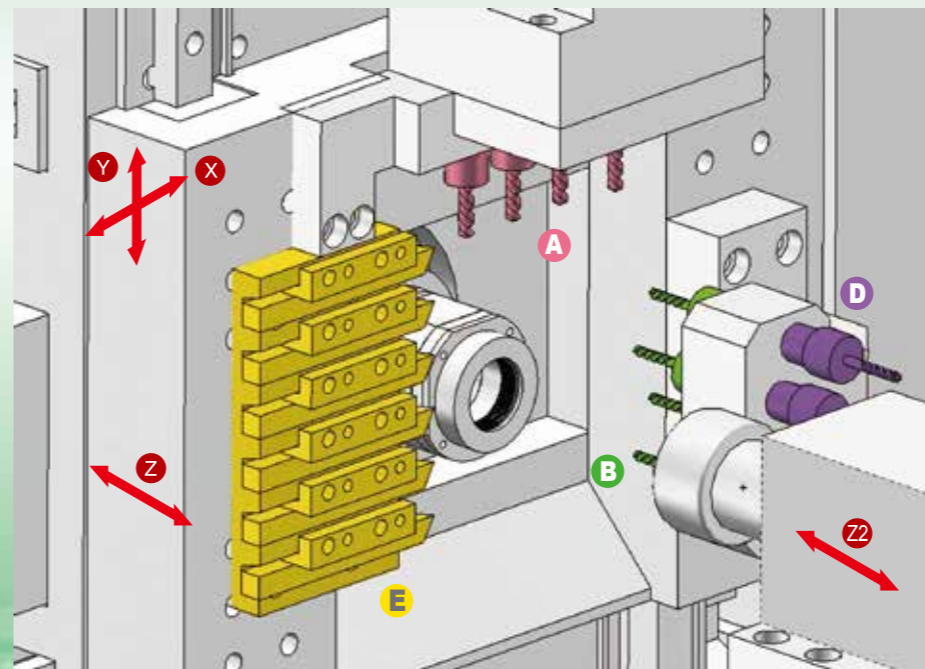

TOOL HOLDER (A)

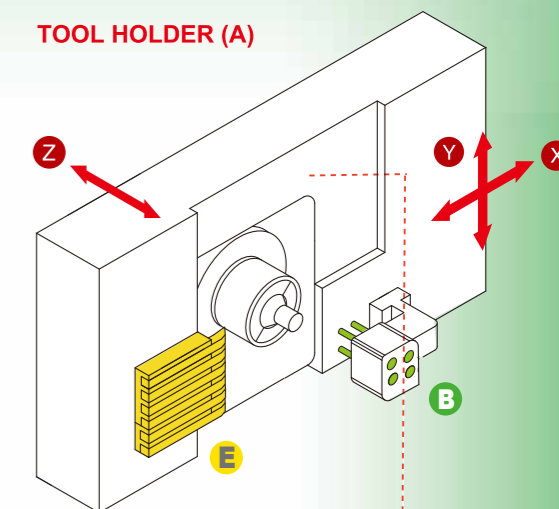

TOOL HOLDER (B)

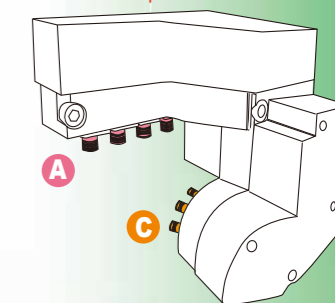

● 機械特點 MACHINE FEATURES :

- **餘料短**
選擇粗料套筒即可走心機當走刀機用，殘料長度約50mm，可有效達到精簡材料成本。
- **粗料加工**
選擇粗料套筒，非研磨棒材也能在走心機加工，材料公差容忍 0.1mm。

- **Short Remnant Material**
With the optional Rough Material Bushing, the remnant material can be 50mm (depending on the parts length).
- **Raw Material Machining**
0.1mm material tolerance can be achieved by using the Rough Material Bushing.

● 選配簡易背軸特點 OPTIONAL SIMPLE SUBSPINDLE FEATURES :

- 解決二次加工問題。
- 省時又省錢。
- Solve the problem of secondary processing.
- Save money and time.

- A** 4 pcs cross working driven tool holder
4 支側面鑽銑刀具刀座
- B** 4 pcs I.D. stationary tool holder
4 支正面內徑刀具刀座
- C** 3 pcs front working driven tool holder(opt.)
3 支正面鑽銑刀具刀座(選配)

- D** 4 pcs back I.D. stationary tool holder
4 支背面固定刀具刀座
- E** 6 pcs O.D. turning tool holder
6 支外徑刀具刀座

主軸配內藏式馬達標準配C軸定位，可選配高解析的CS軸

The main is equipped with built-in motor, standard with C axis orientation, and optional high-analysis CS axis.

